

THIS DRAWING IS UNPUBLISHED. RELEASED FOR PUBLICATION .19

© COPYRIGHT 19 BY AMP INCORPORATED. ALL RIGHTS RESERVED.

LOC	DIST	REVISIONS					
		P	LTR	DESCRIPTION	DATE	DWN	APVD
G	14						
		D		REV PER 0G3A-0658-04	23AUG04	JR	MS

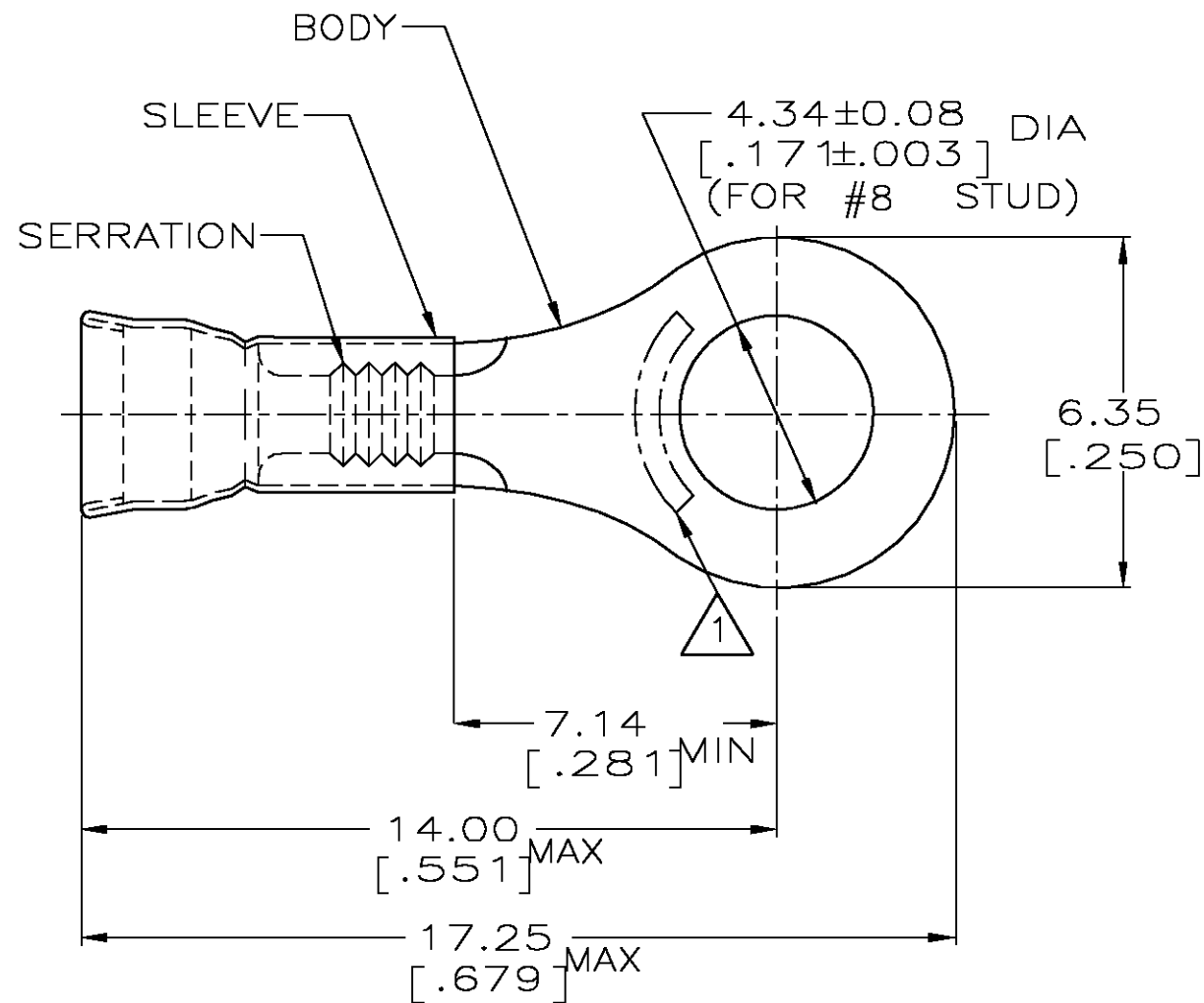

- △ 1 STAMP AMP LOCATE APPROX AS SHOWN
- 2. WIRE INSUL DIA, 1.27-2.08 [.050-.082]
- 3. TONGUE MATL THK, 0.46±0.05 [.018±.002]
- △ 4 GOLD PLATE PER MIL-G45204 OVER NICKEL PLATE PER QQ-N-290
- △ 5 PREPRODUCTION - FASR REQUIRED

1000	LOOSE PIECE	△ 4 △ 5 2-32862-2
5000	ON TAPE, REEL	2-32862-1
1000	LOOSE PIECE	32862
QTY	PACKAGE TYPE	PART NO

AMP INCORPORATED CUSTOMER SERVICE SYSTEM		MAX RECOMMENDED OPERATING TEMPERATURE: -	THIS DRAWING IS A CONTROLLED DOCUMENT FOR AMP INCORPORATED. IT IS SUBJECT TO CHANGE AND THE CONTROLLING ENGINEERING ORGANIZATION SHOULD BE CONTACTED FOR THE LATEST REVISION.		DWN L OLMEDA 23JAN95	AMP AMP Incorporated Harrisburg, PA 17105-3608	
FOR ADDITIONAL PRODUCT INFORMATION OR COPIES OF DRAWINGS AND TECHNICAL DOCUMENTS	PRODUCT INFORMATION CENTER 1-800-522-6752	VOLTAGE RATING: -	DIMENSIONS: mm [in]	TOLERANCES UNLESS OTHERWISE SPECIFIED: 0 PLC ±- 1 PLC ±- 2 PLC ±0.20 [.008] 3 PLC ±- 4 PLC ±- ANGLES ±-	CHK M ELLIS 23JAN95		NAME S BORTNER 23JAN95
FOR APPLICATION TOOLING INFORMATION	TOOLING ASSISTANCE CENTER 1-800-722-1111	CIRCULAR MIL AREA: 0.10mm ² -0.41mm ² [202-810]	MATERIAL BODY, CU, SLV, CU PER ASTM B152		FINISH TIN PLATE PER MIL-T-10727	PRODUCT SPEC -	TERMINAL, RING, DIAMOND GRIP, WIRE SIZE, WIRE SIZE AWG 26-22
FOR ORDER ENTRY	1-800-526-5142	STRANDED WIRE	MATERIAL BODY, CU, SLV, CU PER ASTM B152		FINISH TIN PLATE PER MIL-T-10727	APPLICATION SPEC -	SIZE A3
						WEIGHT -	CAGE CODE 00779
						CUSTOMER DRAWING	DRAWING NO C-32862
							SCALE 6:1
							SHEET 1 OF 1
							REV D